

Installation and operating instructions for Small Immersion Heaters ROTKAPPE® and Small Angular Immersion Heaters ROTKAPPE®

WG 21/07.03/

E-MBA 305a

Our small immersion heaters are intended exclusively for heating process liquids and exclusively for trade and industrial use. In order to ensure correct operation, reliability and a long lifetime, the following must be observed:

1. Electrical Safety

The heaters may be connected only by a qualified electrician, technician or engineer!

Always check that the rated voltage of the units agrees with your supply voltage.

If the small immersion heaters are connected directly to an electrical installation, contactors which disconnect all poles of the supply must be provided (phasebreak 3 mm, see VDE 0720 T1/2.72 § 2, 101). The units must not be connected to the power supply when persons are in contact with the liquid to be heated.

In order to ensure maximum electrical safety, a fault current (FI) circuit breaker should be provided for immersion heaters. The recommended tripping value for this circuit breaker is 30 mA, in accordance with DIN-VDE-Regulation 0664. To avoid malfunction one circuit breaker should protect a maximum of 12 heaters or a maximum of 15 kW.

2. Operating Conditions

Before installation, check that the material of the immersion tube is chemically and mechanically resistant to the liquid to be heated. Avoid electrolytic effects which could damage the metallic immersion tubes, such as polarisation by an electrolytic current (see also our chemical resistance list).

The terminal casing and the lead should not come into direct contact with the liquid or hot steam. The red terminal casing made of polypropylene must be protected by locally provided shields against the effects of strongly oxidising liquids (such as chromic acid or nitric acid).

Immersion tubes made of porcelain or glass must not be subjected to mechanical stress or shocks. The user must provide the necessary protection. If any damage (such as cracks in the immersion tube) is detected, the heater must be taken out of service and disconnected from the supply voltage immediately.

3. Installation

The minimum immersion depth (MET) of the heater is shown by a permanent ring-shaped mark on the immersion tube. The liquid level must never drop below this mark.

The maximum immersion depth is in all cases 50 mm below the lower edge of the terminal casing.

The heated immersion tube surface must not get into contact with heat-sensitive mounting parts or the container wall (minimum distance > 10 mm).

ROTKAPPE® small immersion heaters can be mounted with the aid of a special support HL (accessory) or a rubber mounting sleeve ML on a cross-beam or on the edge of a tank.

ROTKAPPE® small angular immersion heaters can be mounted with the aid of a special support HWL (accessory) on the edge of a tank.

The terminal casing LC has a hole through which a plastic cord can be inserted in order to prevent removal of the small immersion heater from the supports HL and HWL.

The terminal casing LC can also be inserted into a hole with a diameter of 52 mm in a mounting beam or in the tank cover. The height above the beam or cover is in this case 35 mm.

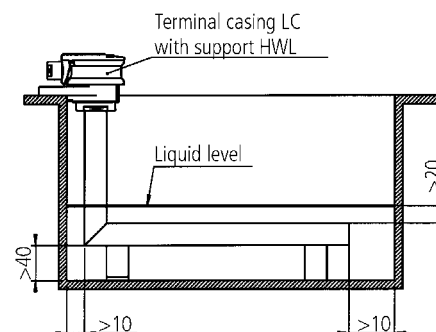
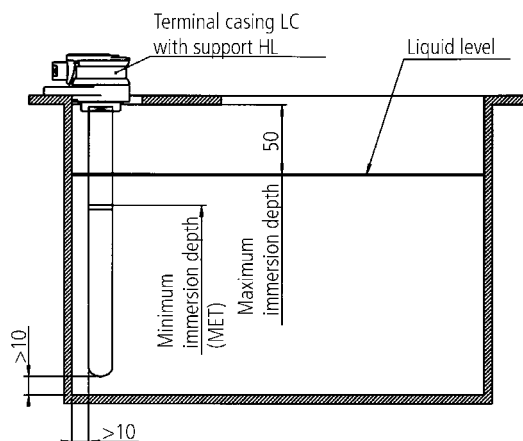

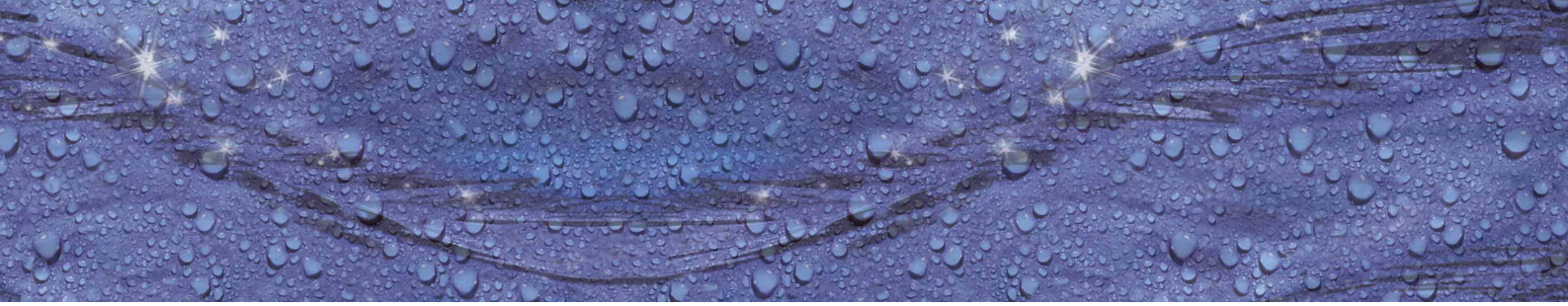

4. Overheating Protection

The user must provide safety precautions such as a level regulation system, to prevent dry operation of the heater (see also our range of accessories).

VDE Regulation VDE 0721, Part 2 A 3, E Part 1, § 10 specifies that electrical heating equipment must be arranged such that there is no possibility of danger to the operator, the surroundings and the materials being heated from the temperature of the electrical heating equipment, even if the equipment is not monitored and/or is switched on inadvertently.

If dangers may result in the case of a fault, such as failure of the temperature controller, a safety device must be provided in order to limit the temperature of the equipment. This safety device must be functionally and electrically separate from the temperature controller. The units conform to thermal safety specifications class 1 provided that safety devices such as a temperature limiter and a thermal cut-out are installed into the container.

After the power has been switched off, the heaters may be removed from the tank, or the tank may be drained, only after the residual heat has been dissipated (about 15 minutes).

Note

At a maximum permissible tube surface load of 4,5 W/cm², the maximum resulting ambient temperature if the heater suddenly runs dry with simultaneous disconnection of the electric power is 50 °C at a distance of 10 mm from the immersion tube.

5. Maintenance and Repair

Any deposits on the immersion tube should be removed at regular intervals. In no case must the deposits be allowed to block the dissipation of heat from the tube, as this will reduce the lifetime of the heater (e.g. incrustation or operation in sludge).

When carrying out repairs, always replace the gaskets of the terminal casing LC in order to maintain its water jet protection (IP 65). If the heater is exposed to aggressive chemicals, we recommend changing the gaskets at regular intervals.

After any repairwork, the small immersion heater should be inspected by a specialist to ensure that it complies with the VDE standards.

6. Opening and Closing the Terminal Casing

The mounting wrench MS (accessory) is used for opening and closing the terminal casing LC and for the installation and removal of heater inserts, immersion tubes and cables.

Degree of protection of terminal casing LC: water-jet proof IP65 (EN 60528).

If you install your own cables, you must remove the white plastic insert below the pull-relief clamp when installing cables with a diameter of >6.5 mm (maximum cable diameter: 9.5 mm).

Take care that the pull-relief, the pressure screw for the cable gland and the cover are tightened securely. The cover of the terminal casing has a shaped piece which snaps into the casing when the cover is correctly closed. This ensures optimum sealing of the casing. The terminal casings are not protected against immersion in liquids by accident.

Non-compliance with these instructions invalidates the warranty.

In case of a claim under guarantee or if any repairs are to be made, please **clean** and **neutralize** the device concerned and return it to our factory freight prepaid.

These Installation and Operating Instructions are also available in German and French.